

SMS Pump Controller



Model: NTSMS-P105

Single Phase SMS/GSM based Pump Controller

Document Ver: 1.0 Date: 20-09-2020

General Description:

Nelso® is the manufacturer of SMS/GSM based Pump Controller. You can control the pump from your smart phone by using our **Free Android Application** or sending SMS/Missed call. It also generates SMS alert when turned Start/Stop by sending SMS Command and giving a missed call.

Features:

- Completely Configurable through App and SMS
- Five mobile numbers can be stored for controlling the device and get message.
- Get SMS alert on every event.
- Automatic Pump On/Off by setting five scheduled timer in a day.
- Start/Stop pump from App or by sending SMS or missed call.
- Password protection to secure from unauthorized uses.
- Over/Under Voltage Protection.
- Dry run protection.
- Stops pump automatically when the overhead tank is full.

Quick installation:

- Make sure that the power switch is off.
- Insert a SIM card with GPRS Data and SMS balance into the SIM card holder.
- Connect 230V AC to the connector of the controller as marked.
- Connect the GSM antenna.
- Connect RL1 and RL2 with the START button and RL3 with the STOP button of your existing panel as described below.
- Turn on the power switch.
- Download Android application from Google Play Store.
- Find serial number written on the device and register it in the android application.

LED Indication:

Yellow LED: Power LED. Continuous On.

Green GSM LED: It blinks every second when searches for network and every 3 seconds upon getting network and every 400ms when GPRS communication is established.

Red OP LED: It turns On when the device is busy, the pump is On and blinks 5 times at the time of sending SMS.

Blinks very fast when SIM Card not detected by the device.

At power on 5 times blink then 1 sec on till network Date-Time not synchronizes.

Configuring the device through SMS:

Save a User No. (*UNx9874228400*) Default - Blank:

All SMS command must be started and ended with * symbol. The device can save up to 5 user's mobile nos. and send SMS alert to them. Registered users can also control (On/Off) the Pump. Factory settings are blank. Anyone can save the first user's no. by sending SMS to the device. After that only registered users can save, delete or alter other user's nos. All mobile nos. should be 10 digits. For example to save the first user no. send SMS ***UN19874228400*** from any mobile no. Now only the first user can save other user's nos. For saving the second user's no. send SMS ***UN29088999888***. Here **UN1** to **UN5** denotes five users.

All commands mentioned here should be from registered mobile numbers only if not specially mentioned.

List of saved user's nos. (*LST*):

Send *LST* to get a list of users in return SMS. You can send this command from any mobile no.

Delete a User No. (*DELx*):

Here x denotes user's position. For example to delete the third user send SMS *DEL3*.

Set scheduled On and Off (*SHDx hh:mm-HH:MM*):

You may set 5 schedules to start and stop the pump on a daily basis. After setting a schedule the controller will switch to Auto mode until you change it from auto to manual mode by sending an SMS. Here x denotes the schedule number and it will be 1,2 or 3 for three schedules. **hh:mm** denotes **from time** and **HH:MM** denotes **to time**. Time is in 24hr format. For example, if you wish to turn the pump on at 5:45PM and Off at 6:05PM then send SMS ***SHD1 17:45-18:05***.

GET saved schedule information (*SHD?*):

Send SMS *SHD?* to get saved schedule list.

Clear particular schedule (*CLR x*):

To clear a saved schedule send SMS *CLR x* where x denotes schedule number and it will be 1 to 5.

Status Report (*STA*):

If you send *STA* then the controller will return pump On/Off Status and mainline status.

Pump On/Off:

Send *ON* from registered mobile to turn the pump On and send *OFF* to turn it off. You can also turn the pump On/Off by calling the device SIM Number. The device will automatically drop the call after a few rings. If you manually On the pump by sending SMS/Missed call, then you also have to off it manually by sending SMS/Missed call or it will stop automatically after the maximum set time. If power fails when the pump is manually On, the pump will On again when power resume.

Manual Mode (*MAN*):

Disable scheduled on/off features. Manual pump On/Off through SMS and miss call.

Auto Mode(*AUTO*) - Default Enabled:

Enable automatic pump On/Off as per schedule. It will be automatically On when you set a schedule.

Auto-generated notification On/Off - Default On:

Send *NON* to On auto-generated notifications feature. You will get SMS notification for every event like pump On/Off, main power On/Off etc. Send *NOF* to turn this feature Off.

Set maximum Pump On-Time(Default 6 Hours):

By sending SMS ***MAX hh:mm*** you can set the maximum continuous pump run time in case you forget to Off it after manual On. Here 'hh' is 2 digit Hour and 'mm' is 2 digit minute (Ex: Send ***MAX 03:45*** to set 3 Hours 45 minute). If you forget to turn off the pump after manual on, the device will send reminder SMS to stop the pump every hour and if you do not take any action then the device will stop the pump automatically after 3 hours 45 minute. To disable this function set the time to '00:00' i.e send ***MAX 00:00***.

Enable/Disable Android App. Support. (*IOTx*) - Default enabled:

Send *IOT1* to enable Android App and send *IOT0* to disable.

Enable/Disable Dry Run Protection. (*DRYx*) - Default disabled:

Send *DRY1* to enable Dry Run Protection and send *DRY0* to disable.

About the device. (*ABT*):

Get information about the device like Hardware/Firmware version, Serial etc.

Factory Settings(*FAC*):

Reset the device to factory settings and erase all stored data.

Android Application:

Download Android Application from Google Play Store by searching keyword "Mobile Pump Controller" or visit

<https://play.google.com/store/apps/details?id=com.nelso.iotpumpcontroller>

Icon of Android Application:



Pump Controller

SMS/GSM based Pump Controller

Working principle:

RL1, RL2 and RL3 are potential-free contacts. RL1 and RL2 are parallel and NO contacts but RL3 is NC contact. The jumper at sense point should be open if the device is connected with a panel which has Green START and Red STOP button. RL1 and RL2 will short to start the pump and then open again after 500 ms together. 2/4 wires from RL1 and RL2 will connect with 2/4 points of green start button parallelly. RL3 will connect in series with any one contact in Red STOP button. This is normally closed contact but to stop the pump it opens for 1 second and again close.

The jumper should be short if the pump is connected with a piano type switch. In that case RL1 and RL2 will remain short until the pump is On. As RL1 and RL2 shorts and opens together, you may use these two relays parallelly to increase the current rating. RL3 has no use in this connection.

In case of power failure, the device will store last state of pump and resume it when it will get power again.

Connection Diagram for MCB/Piano type switch:

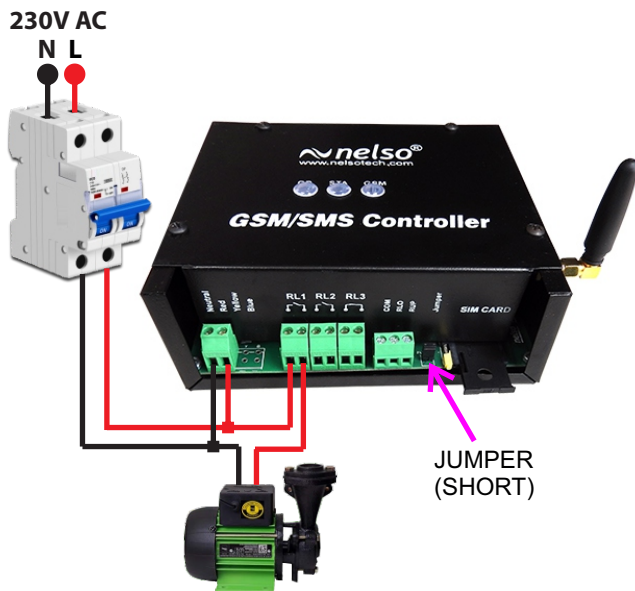

Connection with Direct On Line (DOL) Starter

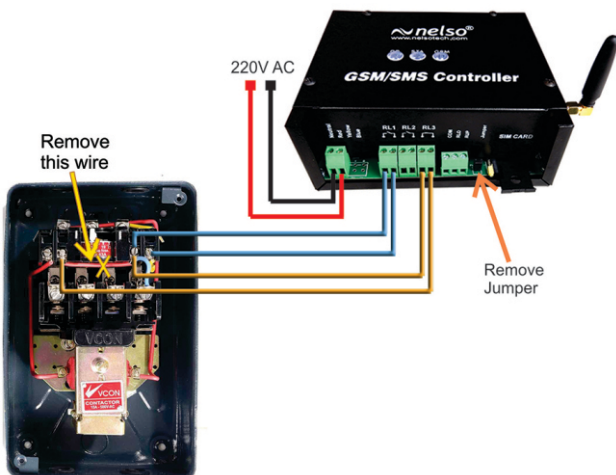

Starter type panel connection diagram:

Control Panel with START and STOP switch and each switch has two terminals (connections) behind it.

Note: Must keep the jumper open (Extended Mode).

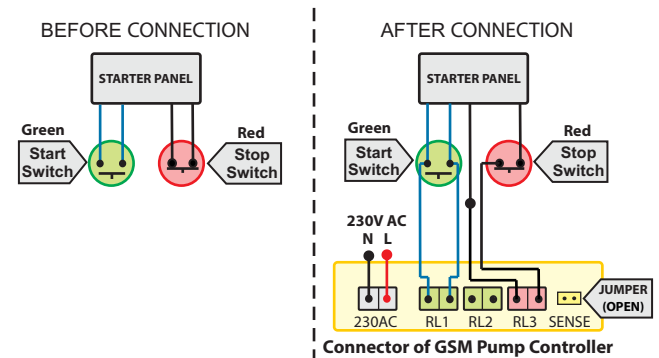

Control Panel with START and STOP switch and START switch has four terminals (connections) behind it.

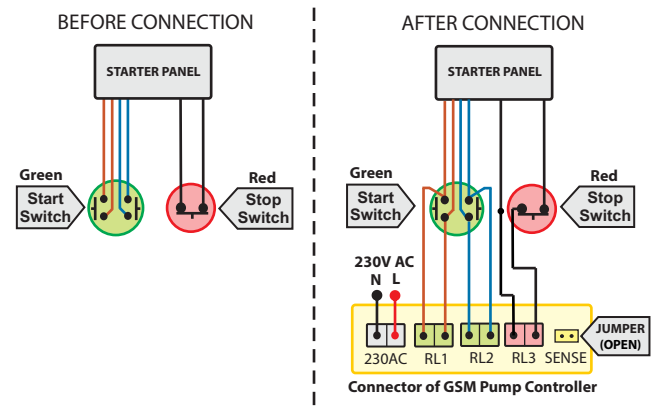

Nelso Technology Pvt. Ltd.

P-96, Sreebhumi, Ichapur,

24PGS(N), 743144,

West Bengal, India

Web: www.nelsotech.com

Email: info@nelsotech.com

Mob: +91-6293-666-222